

阅读申明

- 1.本站收集的数据手册和产品资料都来自互联网，版权归原作者所有。如读者和版权方有任何异议请及时告之，我们将妥善解决。
- 2.本站提供的中文数据手册是英文数据手册的中文翻译，其目的是协助用户阅读，该译文无法自动跟随原稿更新，同时也可能存在翻译上的不当。建议读者以英文原稿为参考以便获得更精准的信息。
- 3.本站提供的产品资料，来自厂商的技术支持或者使用者的心得体会等，其内容可能存在描述上的差异，建议读者做出适当判断。
- 4.如需与我们联系，请发邮件到marketing@iczoom.com，主题请标有“数据手册”字样。

Read Statement

1. The datasheets and other product information on the site are all from network reference or other public materials, and the copyright belongs to the original author and original published source. If readers and copyright owners have any objections, please contact us and we will deal with it in a timely manner.
2. The Chinese datasheets provided on the website is a Chinese translation of the English datasheets. Its purpose is for reader's learning exchange only and do not involve commercial purposes. The translation cannot be automatically updated with the original manuscript, and there may also be improper translations. Readers are advised to use the English manuscript as a reference for more accurate information.
3. All product information provided on the website refer to solutions from manufacturers' technical support or users the contents may have differences in description, and readers are advised to take the original article as the standard.
4. If you have any questions, please contact us at marketing@iczoom.com and mark the subject with "Datasheets" .

Enhanced Quadruple Mode PWM Flyback Controller

General Description

R7732 series is the successor of R7730/1 and fully compatible with most of SOT-23-6 product so far in the market. It's an enhanced, high-performance and current mode PWM controller. It focuses on "easy to design" in different applications and it will save both design effort and external components.

Besides the general features shown in the Features section, R7732 covers wide protection options, such as internal Over Load Protection(OLP) and Over Voltage Protection(OVP) to eliminate the external protection circuits. Moreover, it also features Secondary Rectifier Short Protection(SRSP) and CS pin open protection. This protection will make the PSU design for reliability and safety easier.

R7732 is designed for power supply such as NB adaptor which is a very cost effective and compact design. The precise external OVP and Over Temperature Protection (OTP) can be implemented by very simple circuit. The start-up resistors can also be replaced by bleeding resistors to save power loss and component count.

Features

- UVLO 9V/14V
- Soft Start Function
- Current Mode Control
- Built-in Slope Compensation
- Internal Leading Edge Blanking
- PWM Quadruple Mode for Green-Mode
- Excellent Green Power Performance
- Cycle-by-Cycle Current Limit
- Internal Over Voltage Protection
- Internal Over Load Protection
- Secondary Rectifier Short Protection
- Opto-Coupler Short Protection
- Feedback Open-Loop Protection
- CS Pin Open Protection
- Built-in Jittering Frequency
- Built-in PRO Pin for External Arbitrary OVP/OTP
- Soft Driving for EMI Noise
- High Noise Immunity
- RoHS Compliant and Halogen Free

R7732 Version Table

Version	R7732G	R7732R	R7732L	R7732A	R7732H
Frequency	65kHz	65kHz	65kHz	65kHz	100kHz
OLP Delay Time	56ms	56ms	56ms	28ms	36ms
Internal OVP(27V)	Auto Recovery	Auto Recovery	Latch	Latch	Auto Recovery
OLP & SRSP	Auto Recovery	Auto Recovery	Auto Recovery	Latch	Auto Recovery
PRO Pin High	Latch	Auto Recovery	Latch	Latch	Auto Recovery
PRO Pin Low	Auto Recovery	Latch	Latch	Latch	Latch

Pin Configurations

(TOP VIEW)

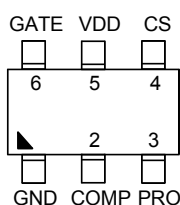

SOT-23-6

www.DataSheet4U.com

Application

- Switching AC/DC Adaptor and Battery Charger
- Printer Power Supply
- DVD Open Frame Power Supply
- Set-Top Box (STB)
- ATX Standby Power
- TV/Monitor Standby Power
- PC Peripherals
- NB Adaptor

Ordering Information

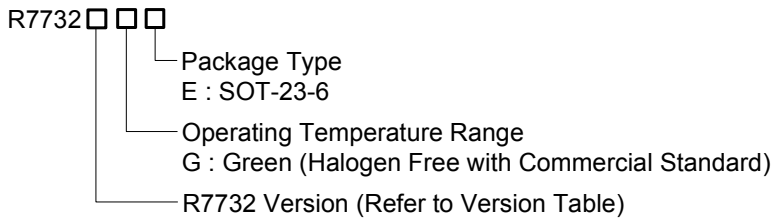

Note :

Richpower Green products are :

- ▶ RoHS compliant and compatible with the current requirements of IPC/JEDEC J-STD-020.
- ▶ Suitable for use in SnPb or Pb-free soldering processes.

Marking Information

For marking information, contact our sales representative directly or through a Richpower distributor located in your area, otherwise visit our website for detail.

Typical Application Circuit

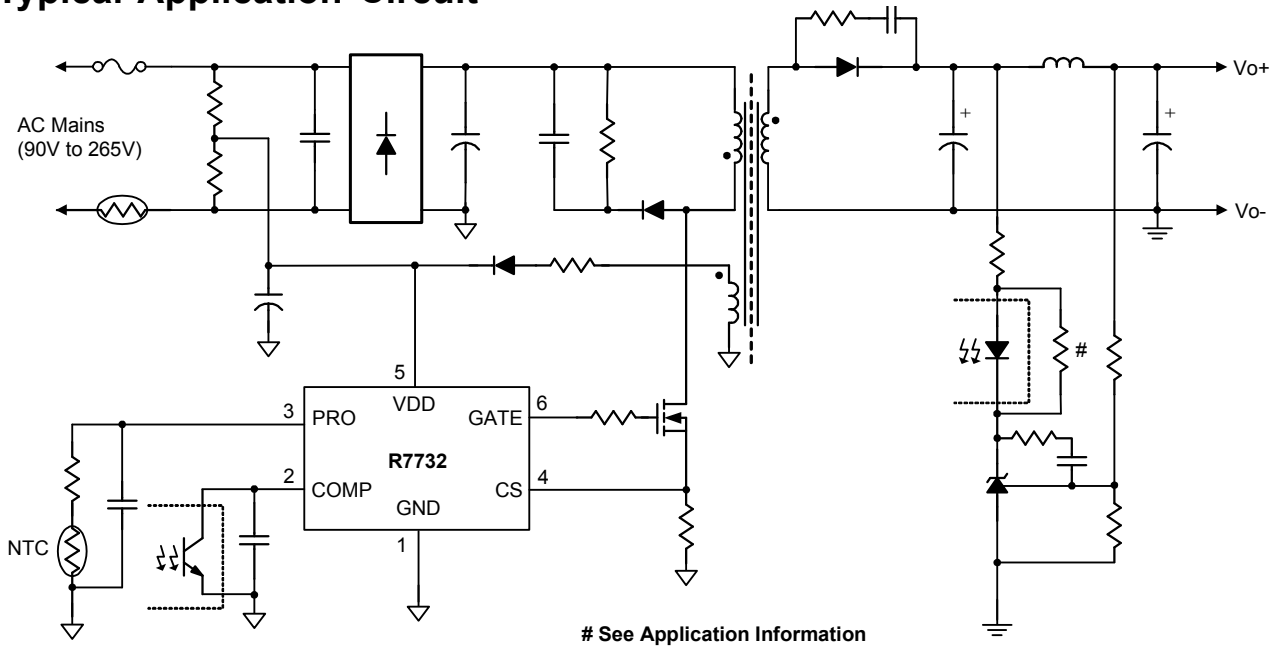

Pin Description

Pin No.	Pin Name	Pin Description
1	GND	Ground.
2	COMP	Voltage feedback pin. By connecting an opto-coupler to close control loop and achieve the regulation.
3	PRO	For external arbitrary OVP or OTP.
4	CS	Primary current sense pin.
5	VDD	Power supply pin.
6	GATE	Gate drive output to drive the external MOSFET.

Block Diagram

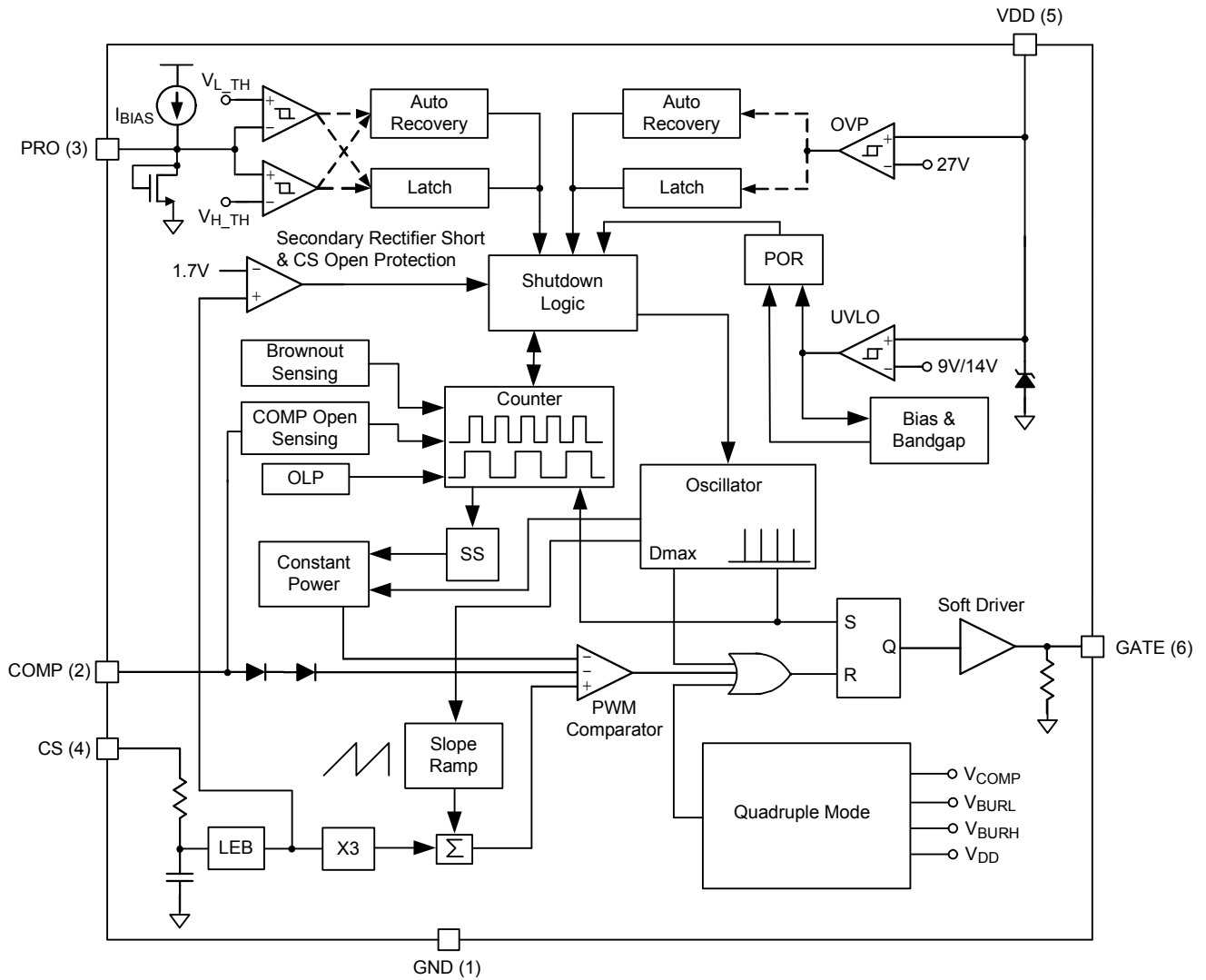

Absolute Maximum Ratings (Note 1)

- Supply Input Voltage, V_{DD} ----- -0.3V to 30V
- GATE Pin ----- -0.3V to 16.5V
- PRO, COMP, CS Pin ----- -0.3V to 6.5V
- I_{DD} ----- 10mA
- Power Dissipation, $P_D @ T_A = 25^\circ C$
 SOT-23-6 ----- 0.4W
- Package Thermal Resistance (Note 2)
 SOT-23-6, θ_{JA} ----- $250^\circ C/W$
- Junction Temperature ----- $150^\circ C$
- Lead Temperature (Soldering, 10 sec.) ----- $260^\circ C$
- Storage Temperature Range ----- $-65^\circ C$ to $150^\circ C$
- ESD Susceptibility (Note 3)
 HBM (Human Body Mode) ----- 3kV
 MM (Machine Mode) ----- 250V

Recommended Operating Conditions (Note 4)

- Supply Input Voltage, V_{DD} ----- 12V to 25V
- Ambient Temperature Range ----- $-40^\circ C$ to $85^\circ C$

Electrical Characteristics

($V_{DD} = 15V$, $T_A = 25^\circ C$, unless otherwise specified)

Parameter	Symbol	Conditions	Min	Typ	Max	Unit
VDD Section						
V_{DD} Over Voltage Protection Level	V_{OVP}		26	27	28	V
V_{DD} Zener Clamp	V_Z		29	--	--	V
On Threshold Voltage	V_{TH_ON}		13	14	15	V
Off Threshold Voltage	V_{TH_OFF}		8.5	9	9.5	V
VDD Holdup Mode Entry Point	V_{DD_LOW}	$V_{COMP} < 1.6V$	--	10	--	V
VDD Holdup Mode Ending Point	V_{DD_HIGH}	$V_{COMP} < 1.6V$	--	10.5	--	V
Start-up Current	I_{DD_ST}	$V_{DD} = V_{TH_ON} - 0.2V$, $T_A = -40^\circ C$ to $100^\circ C$	--	20	35	μA
Operating Supply Current	I_{DD_OP}	$V_{DD} = 15V$, $V_{COMP} = 2.5V$, GATE pin open	--	1.3	2.2	mA
Latch-off Operating Current	I_{DD_LH}	$T_A = -40^\circ C$ to $100^\circ C$	--	--	40	μA

To be continued

Parameter	Symbol	Conditions	Min	Typ	Max	Unit
Oscillator Section						
Normal PWM Frequency	f _{OSC}	R7732G/R/L/A	60	65	70	kHz
		R7732H	92	100	108	
Frequency Reduction Mode Minimum Frequency	f _{FR_MIN}	R7732G/R/L/A	18	22	--	kHz
		R7732H	--	25	--	
Maximum Duty Cycle	DCY _{MAX}		70	75	80	%
PWM Frequency Jitter Range	Δf		--	±6	--	%
PWM Frequency Jitter Period	T _{JIT}	For 65kHz	--	4	--	ms
Frequency Variation Versus V _{DD} Deviation	f _{DV}	V _{DD} = 12V to 25V	--	--	2	%
Frequency Variation Versus Temperature Deviation	f _{DT}	T _A = -30°C to 105°C (Note 5)	--	--	5	%
COMP Input Section						
Open-Loop Voltage	V _{COMP_OP}	COMP pin open	5.5	5.75	6	V
COMP Open-Loop Protection Delay Time	T _{OLP}	R7732G/R/L	--	56	--	ms
		R7732A	--	28	--	
		R7732H	--	36	--	
Short Circuit Current	I _{ZERO}	V _{COMP} = 0V	--	1.2	2.2	mA
Frequency Reduction Mode Entry Voltage	V _{FR_ET}		--	3	--	V
Frequency Reduction Mode Ending Voltage	V _{FR_ED}	R7732G/R/L/A	--	2.9	--	V
		R7732H	--	2.8	--	
Current-Sense Section						
Initial Peak Current Limitation Offset	V _{CS_TH}		0.68	0.7	0.72	V
Leading Edge Blanking Time	T _{LEB}	(Note 6)	150	250	350	ns
Internal Propagation Delay Time	T _{PD}	(Note 6)	--	100	--	ns
Minimum On Time	T _{ON_MIN}		250	350	450	ns
GATE Section						
Rising Time	T _R	V _{DD} = 15V, C _L = 1nF	--	125	--	ns
Falling Time	T _F	V _{DD} = 15V, C _L = 1nF	--	40	--	ns
GATE Output Clamping Voltage	V _{CLAMP}	V _{DD} = 25V	--	14	--	V

Parameter	Symbol	Conditions	Min	Typ	Max	Unit
PRO Interface Section						
Pull Low Threshold	V_{L_TH}		0.47	0.5	0.53	V
Pull High Threshold	V_{H_TH}		3.5	3.8	4.1	V
Internal Bias Current	I_{BIAS}		90	100	110	μA
Pull High Sinking Current	I_{SINK}	(Note 7)	--	--	1.2	mA

Note 1. Stresses beyond those listed under “ Absolute Maximum Ratings” may cause permanent damage to the device.

These are stress ratings only, and functional operation of the device at these or any other conditions beyond those indicated in the operational sections of the specifications is not implied. Exposure to absolute maximum rating conditions for extended periods may affect device reliability.

Note 2. θ_{JA} is measured in the natural convection at $T_A = 25^\circ C$ on a low effective single layer thermal conductivity test board of JEDEC 51-3 thermal measurement standard.

Note 3. Devices are ESD sensitive. Handling precaution is recommended.

Note 4. The device is not guaranteed to function outside its operating conditions.

Note 5. Guaranteed by design.

Note 6. Leading edge blanking time and internal propagation delay time are guaranteed by design.

Note 7. The sourcing current of PRO pin must be limited below 5mA. Otherwise it may cause permanent damage to the device.

Typical Operating Characteristics

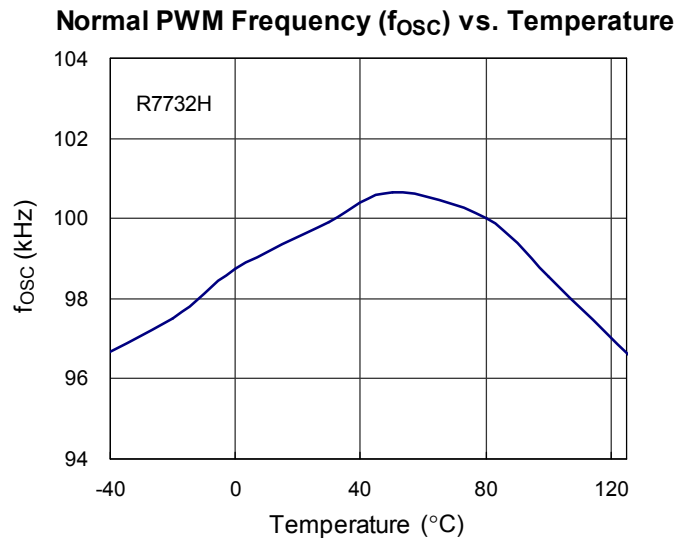
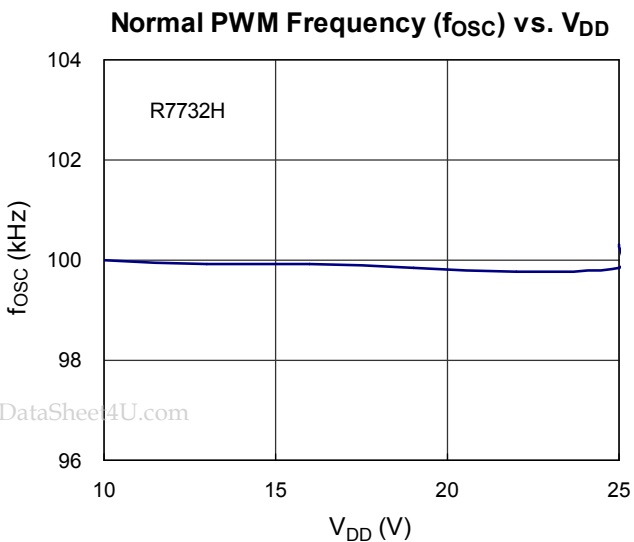
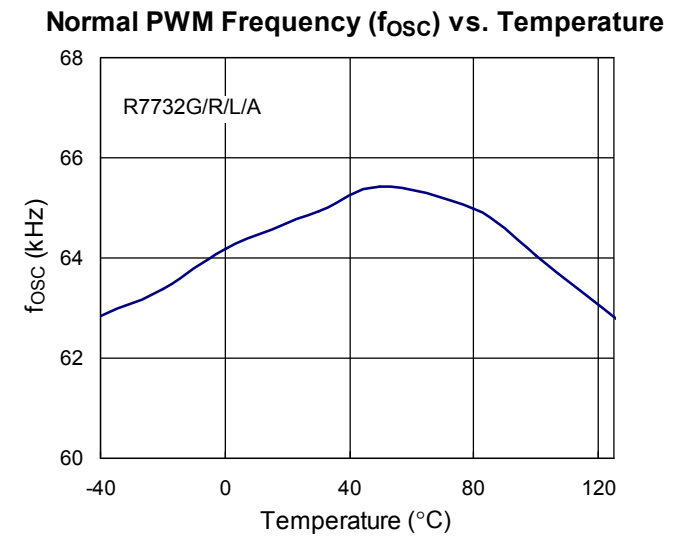
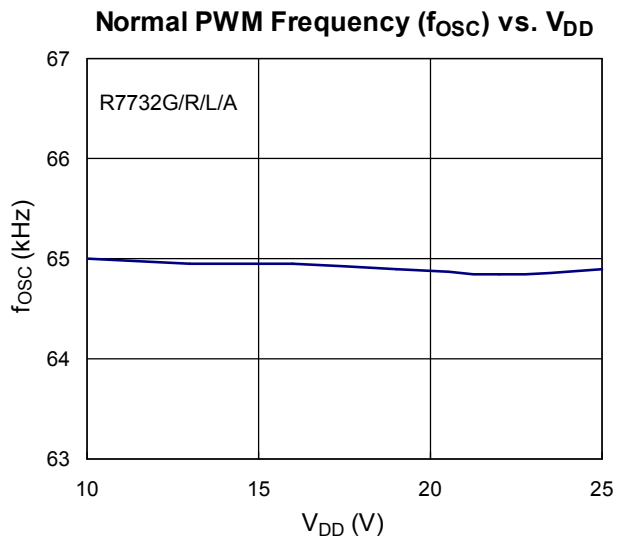
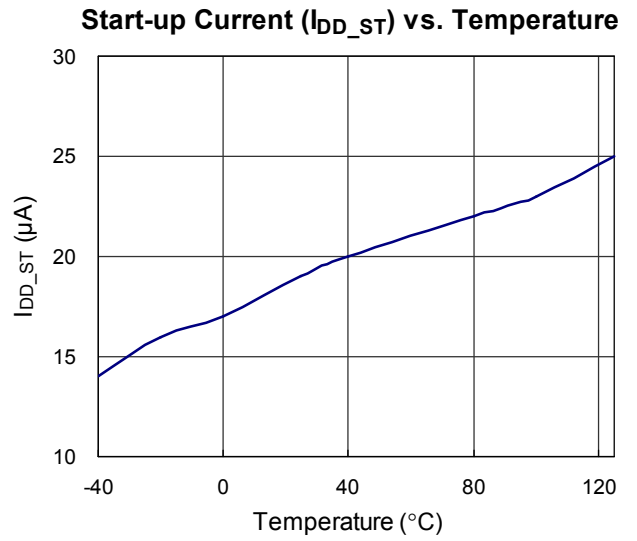
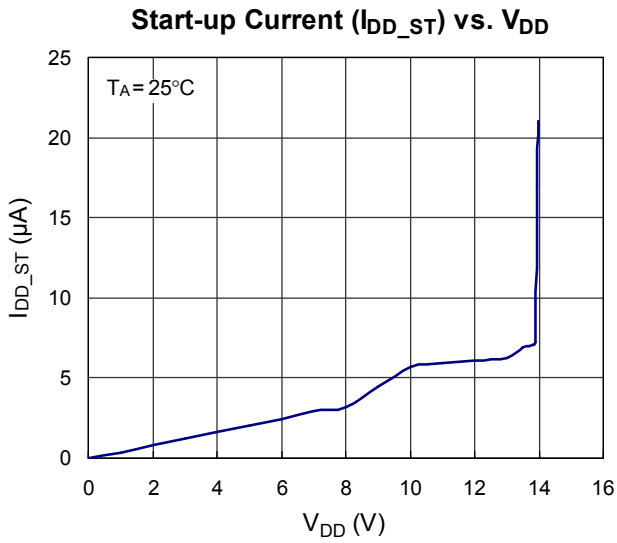

www.DataSheet4U.com

On Threshold Voltage (V_{TH_ON}) vs. Temperature

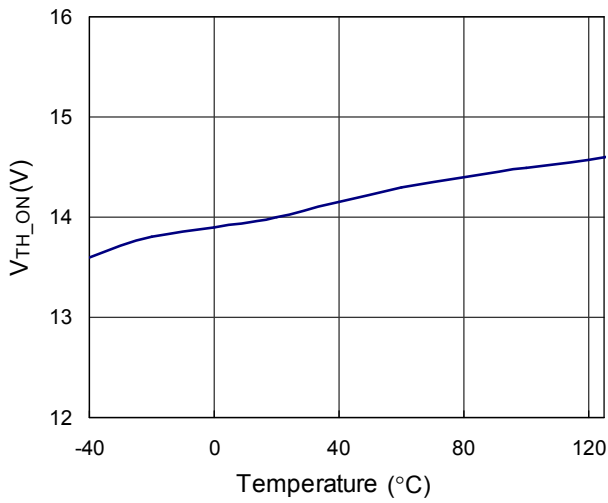

Off Threshold Voltage (V_{TH_OFF}) vs. Temperature

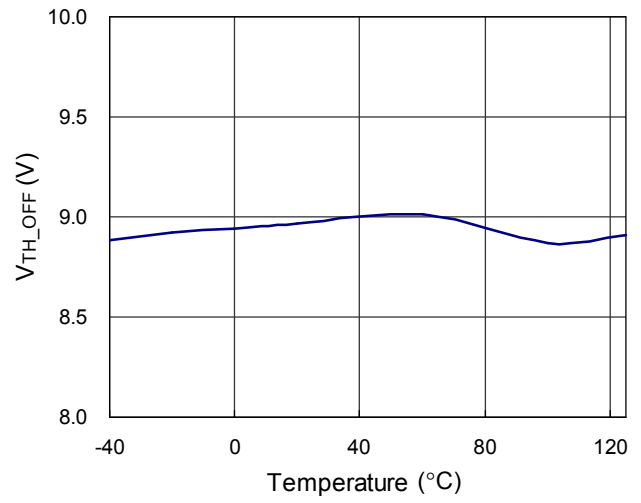

Frequency Reduction Mode Minimum Frequency (f_{FR_MIN}) vs. Temperature

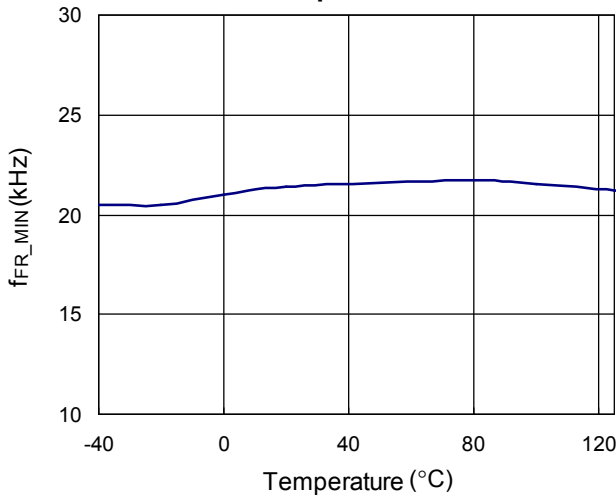

Operating Supply Current (I_{DD_OP}) vs. Temperature

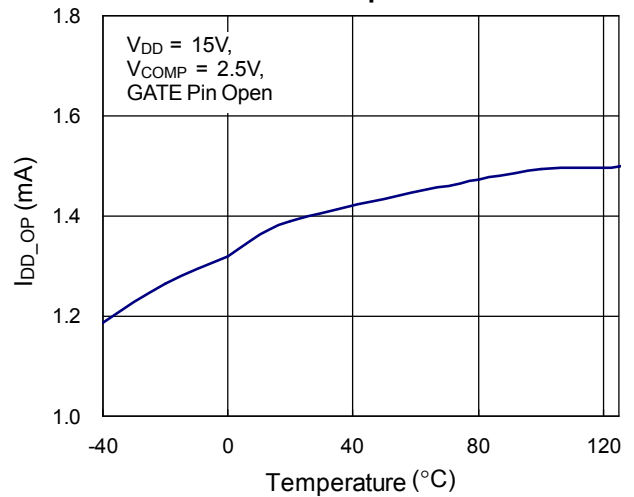

COMP Open-Loop Voltage (V_{COMP_OP}) vs. Temperature

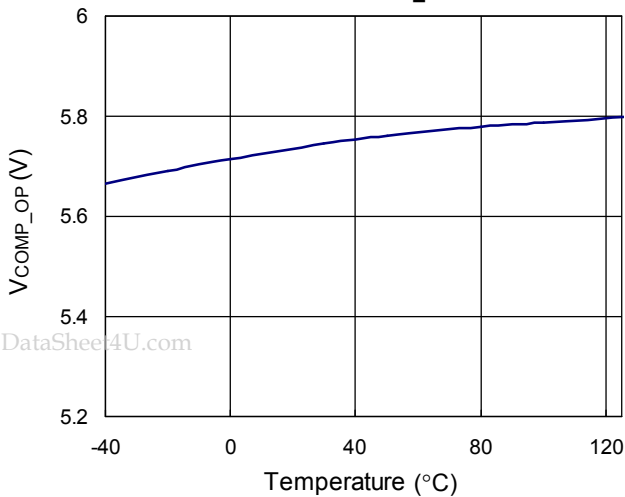

V_{DD} Over Voltage Protection (V_{OVP}) vs. Temperature

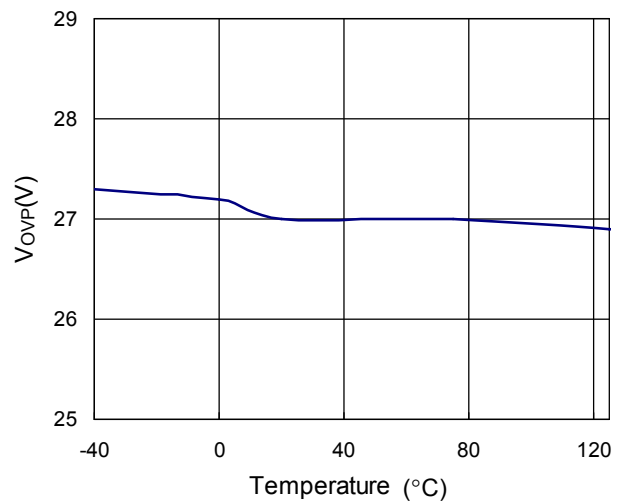

www.DataSheet4U.com

OLP Delay Time (T_{OLP}) vs. Temperature

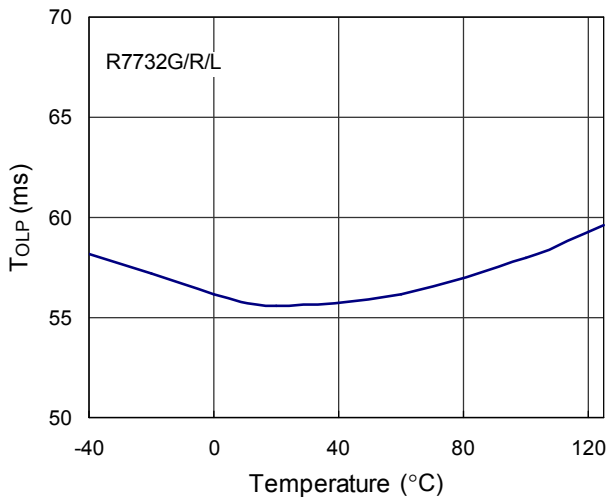

OLP Delay Time (T_{OLP}) vs. Temperature

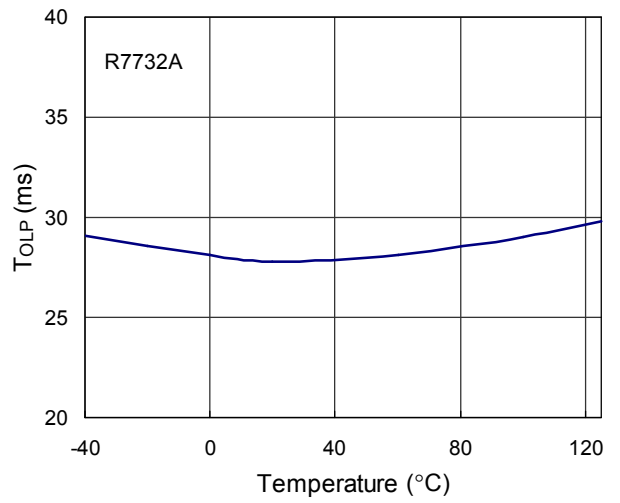

OLP Delay Time (T_{OLP}) vs. Temperature

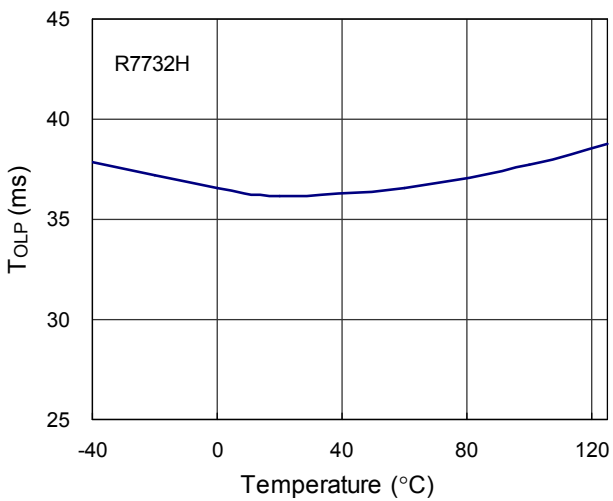

Initial Peak Current Limitation Offset (V_{CS_TH}) vs. Temperature

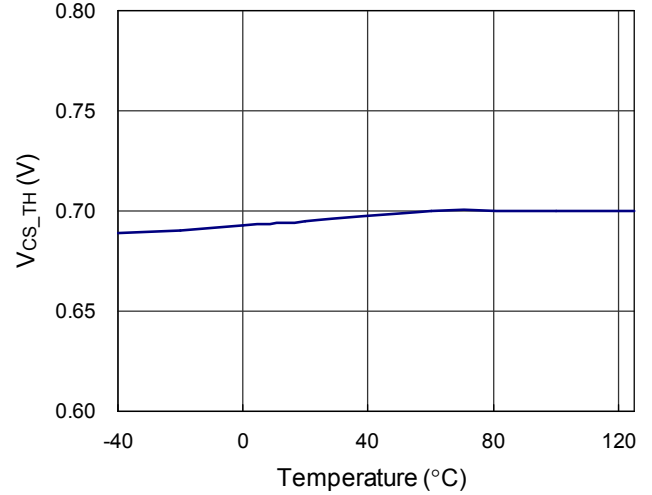

Latch-off Operating Current (I_{DD_LH}) vs. Temperature

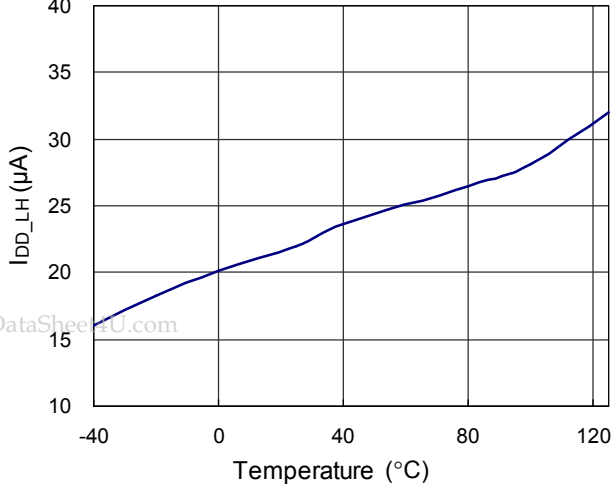

PRO Pin Internal Bias Current (I_{BIAS}) vs. Temperature

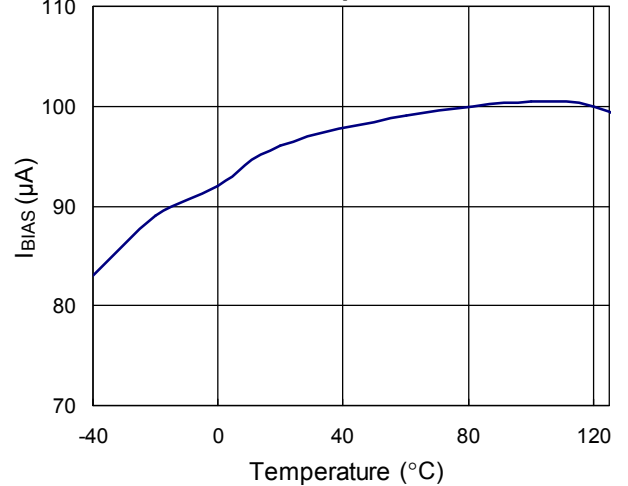

www.DataSheet4U.com

PRO Pin Pull High Threshold (V_{H_TH}) vs. Temperature

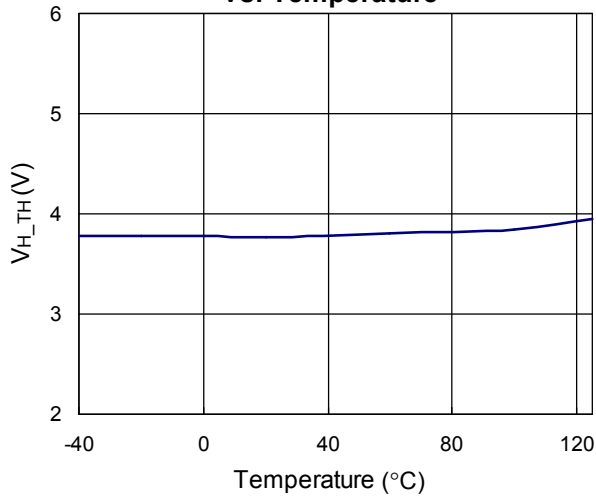

PRO Pin Pull Low Threshold (V_{L_TH}) vs. Temperature

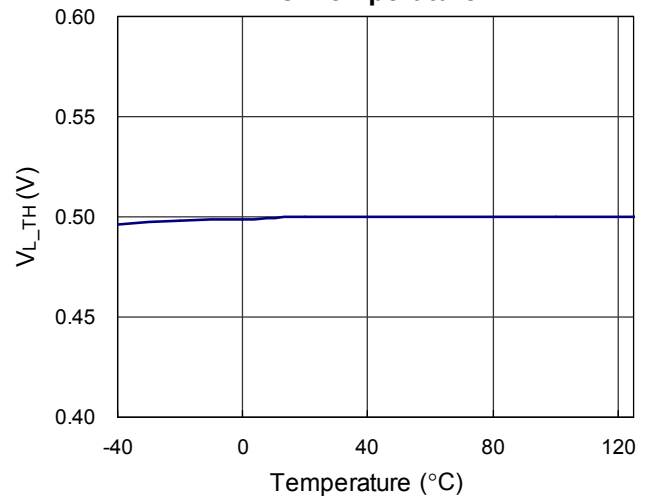

Rising Time (T_R) vs. Temperature

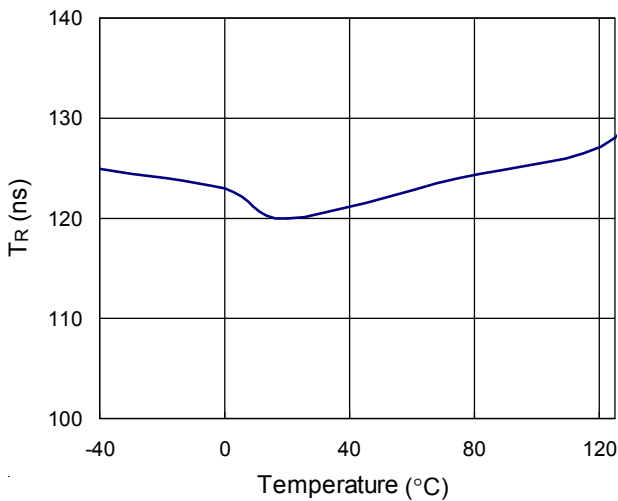

Falling Time (T_F) vs. Temperature

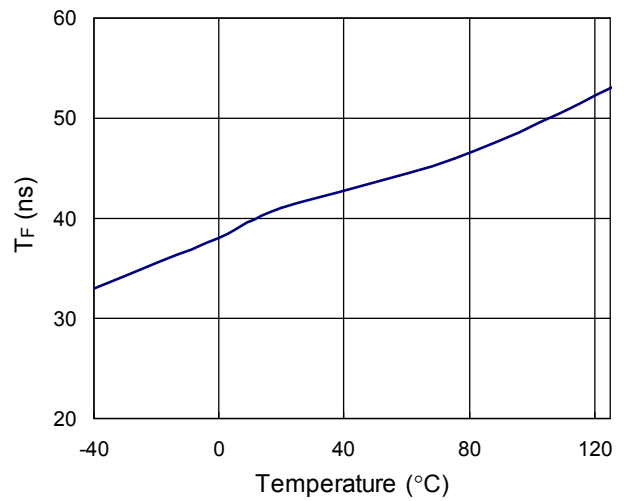

GATE Clamping Voltage (V_{CLAMP}) vs. Temperature

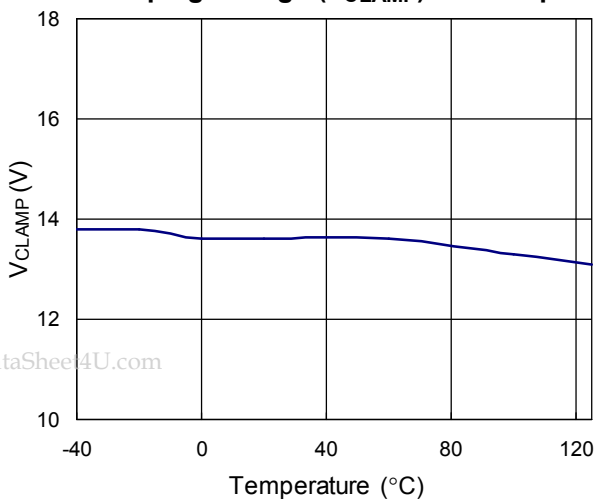

Maximum Duty Cycle (DCY_{MAX}) vs. Temperature

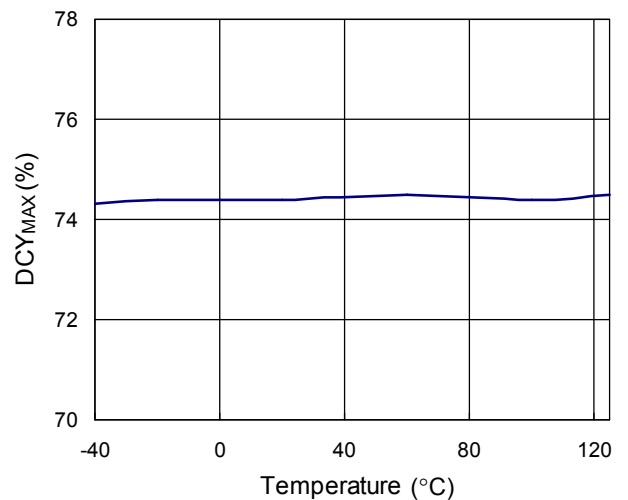

www.DataSheet4U.com

Application Information

PWM Quadruple Mode

R7732 applies quadruple mode for improving efficiency at light load operation. Please also refer to Figure 1 for details.

- **PWM Mode** : For most of load, the circuit will run at traditional PWM current mode.

#It's highly recommended to add a resistor in parallel with opto-coupler. To provide sufficient bias current to make TL-431 regulate properly, 1.2kΩ resistor is suggested.

- **Frequency Reduction Mode** : The frequency reduction mode function provides linear switching frequency reduction according to load conditions, as shown in Figure 2. When the feedback voltage of COMP pin is lower than V_{FR_ET} , the switching frequency starts to decrease. When the power supply is at light-load and the feedback voltage of COMP pin lower than V_{FR_ED} , the switching frequency is clamped at f_{FR_MIN} . This frequency reduction mode function reduces power consumption under light-load and no-load conditions, and easily meets even the strictest regulations.

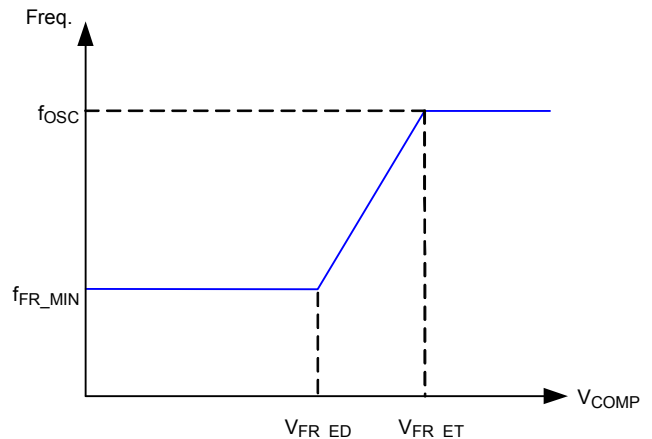

Figure 2. PWM Frequency vs. COMP Voltage

- **Burst Mode** : During light load, switching loss will dominate the power efficiency calculation. This mode is to cut switching loss. As shown in Figure 1, when the output load gets light, feedback signal drops and touches V_{BURL} . PWM signal will be blanked and system ceases to switch. After V_{OUT} drops and feedback signal goes back to V_{BURH} , switching will be resumed.

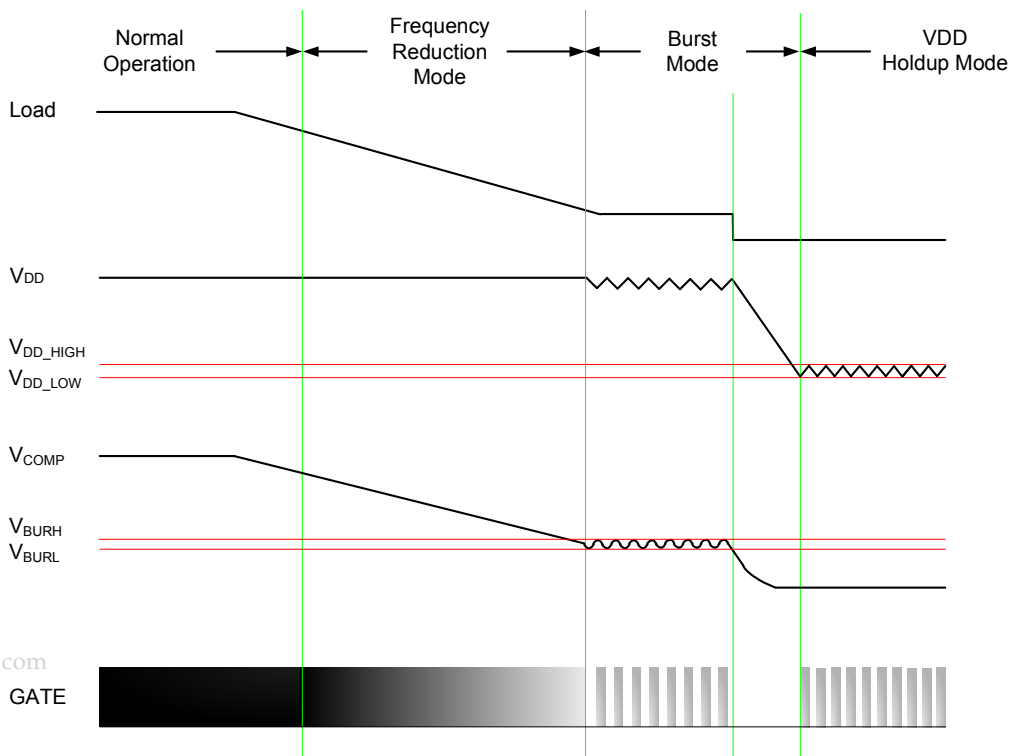

Figure 1. PWM Quadruple Mode

• **VDD Holdup Mode:** Under light load or load transient moment, feedback signal will drop and touch V_{BURL} . Then PWM signal will be blanked and system ceases to switch. V_{DD} could drop down to turn off threshold voltage. To avoid this, when V_{DD} drops to a setting threshold, 10V, the hysteresis comparator will bypass PWM and burst mode loop and forces switching at a very low level to supply energy to VDD pin. VDD holdup mode was also improved to hold up V_{DD} by less switching cycles. This mode is very useful in reducing start-up resistor loss while still get start-up time in spec. It's not likely for V_{DD} to touch UVLO turn off threshold during any light load condition. This will also makes bias winding design and transient design easier.

Furthermore, VDD holdup mode is only designed to prevent V_{DD} from touching turn off threshold voltage under light load or load transient moment. Relative to burst mode, switching loss will increase on the system at VDD holdup mode, so it is highly recommended that the system should avoid operating at this mode during

light load or no load condition, normally.

Start-up Circuit

To minimize power loss, it's recommended that the start-up current is from bleeding resistor. It's not only good for power saving but also could reset latch mode protection quickly. Figure 3 shows I_{DD_Avg} vs. $R_{Bleeding}$ curve. User can apply this curve to design the adequate bleeding resistor.

Gate Driver

A totem pole gate driver is fine tuned to meet both EMI and efficiency requirement in low power application. An internal pull low circuit is activated after pretty low V_{DD} to prevent external MOSFET from accidentally turning on during UVLO.

Oscillator

To guarantee precise frequency, it's trimmed to 5% tolerance. It also generates slope compensation saw-tooth, 75% maximum duty cycle pulse and overload protection

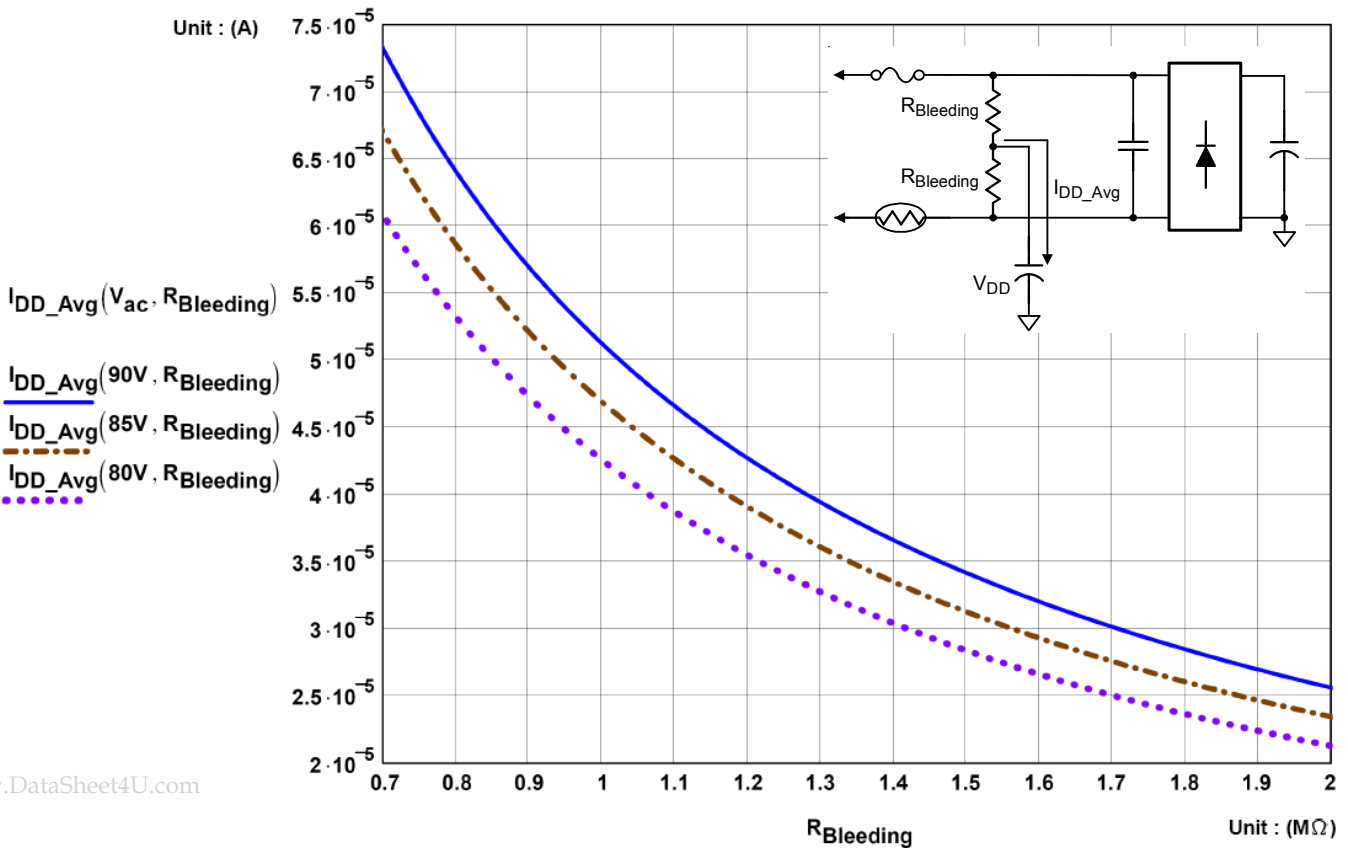

Figure 3. I_{DD_Avg} vs. $R_{Bleeding}$ Curve

slope. It can typically operate at built-in 65kHz center frequency and features frequency jittering function. Its jittering depth is 6% with about 4ms envelope frequency at 65kHz.

Tight Current Limit Tolerance

Since R7732 is the successor of R7731A, its current limit setting is completely the same as R7731A. Generally, the saw current limit applied to low cost flyback controller because of simple design. However, saw current limit is hard to test in mass production. Therefore, it's generally "guaranteed by design". The variation of process and package will make its tolerance wider. It will lead to 20% to 30% variation when doing OLP test at certain line voltage. This will cause yield loss in power supply mass production. Through well foundry control, design and test / trim mode in final test, R7732 current limit tolerance is tight enough to make design easier.

PRO Pin Application

R7732 features a PRO pin, as shown in Figure 4, and it can be applied for external arbitrary OVP or OTP.

If the voltage of PRO pin is greater than pull-low threshold V_{L_TH} , the controller is enabled and switching will occur. If the voltage of PRO pin falls below pull-low threshold or rises to pull-high threshold V_{H_TH} , the controller will be shut down and cease to switch after deglitch delay.

PRO pin is built in 1.5V internally, so leave PRO pin open if you don't need this function. If designer needs to apply a bypass capacitor on PRO pin, it should not be more than 1nF. The internal bias current of PRO pin is 100µA(Typ.). R7732 has internal OVP. For arbitrary OVP or OTP applications which behave as auto recovery or latch, it can get these by PRO pin. For PRO pin pulling high function applications, the voltage of PRO pin must rise above V_{H_TH} (The supply current of PRO pin must be greater than 1.2mA and be limited below 5mA.). When IC enters latch mode, the IC maximum operating current is 60µA(100°C), and it will be release until V_{DD} is fallen to V_{TH_OFF} .

PRO pin is guaranteed that below: If the voltage of PRO pin reaches 4.1V or falls below 0.47V, the system will be protected.

Soft Start

During initial power on, especially at high line, current spike is kind of unlimited by current limit. Therefore, besides cycle-by-cycle current limiting, R7732 still provides soft start function. It effectively suppresses the stat-up current spike. The typical soft start duration is about 40 clock cycles. This will provide more reliable operation and possibility to use smaller current rating power MOSFET.

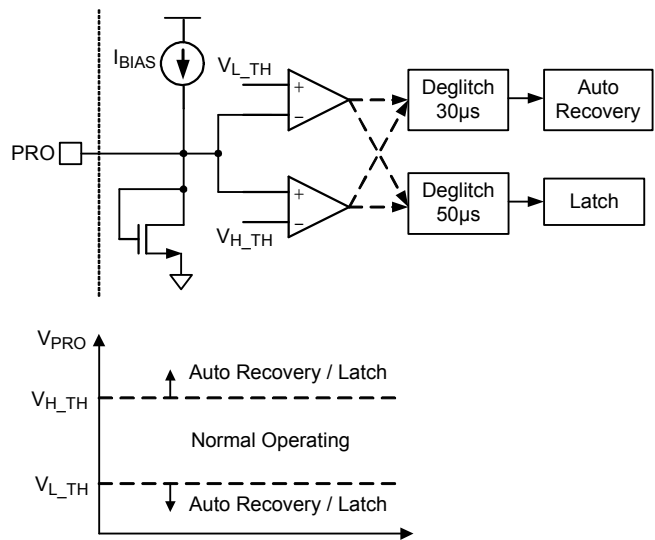

Figure 4. PRO Pin Diagram

Protection

R7732 provide fruitful protection functions that intend to protect system from being damaged. All the protection functions can be listed as below:

- **Cycle-by-Cycle Current Limit:** This is a basic but very useful function and it can be implemented easily in current mode controller.
- **Over Load Protection:** Long time cycle-by-cycle current limit will lead to system thermal stress. To further protect system, system will be shut down after 56ms (R7732A: 28ms; R7732H: 36ms).

Through our proprietary prolong turn off period during hiccup(R7732A: latch), the power loss and thermal during OLP will be averaged to an acceptable level over the ON/OFF cycle of the IC. This will last until fault is removed.

- **Brownout Protection:** During heavy load, this will trigger 56ms(R7732A: 28ms; R7732H: 36ms) protection and shut down the system. If it is in light load condition, system will be shut down after V_{DD} is running low and triggers UVLO.
- **CS Pin Open Protection:** When CS pin is opened, the system will be shut down after couples of cycle. It could pass CS pin open test easier.
- **Over Voltage Protection:** Output voltage can be roughly sensed by VDD pin. If the sensed voltage reaches 27V threshold, system will be shut down and hiccup after 20 μ s deglitch delay for R7732G/R/H or latch after 70 μ s deglitch delay for R7732L/A. This will last until fault is removed.
- **Feedback Open and Opto-Coupler Short:** This will trigger OVP or OLP. It depends on which one occurs first.
- **Secondary Rectifier Short Protection:** As shown in Figure 5. The current spike during secondary rectifier short test is extremely high because of the saturated main transformer. Meanwhile, the transformer acts like a leakage inductance. During high line, the current in power MOSFET is sometimes too high to wait for OLP delay time. To offer better and easier protection design, R7732 shut down the controller after couples of cycles before fuse is blown up.

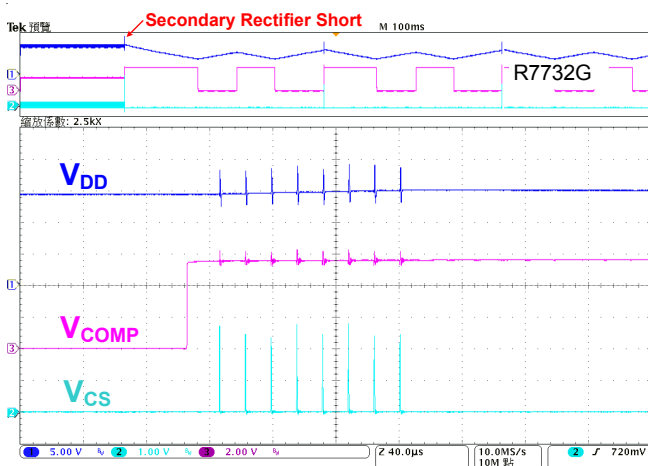
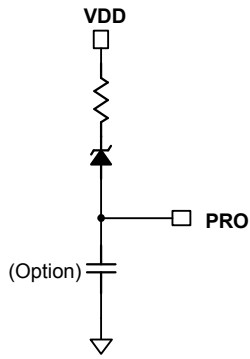

Figure 5. Secondary Rectifier Short Protection

www.DataSheet4U.com

PRO Pin Typical Application Circuit



$V_{DD} \text{ OVP} : V_{DD} > V_R + V_Z + 3.8V$

Figure 6. For VDD OVP Only

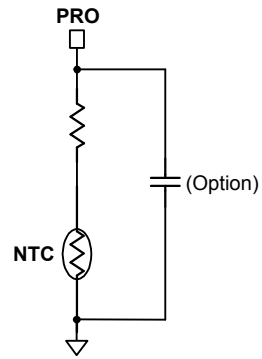

Figure 7. For OTP Only

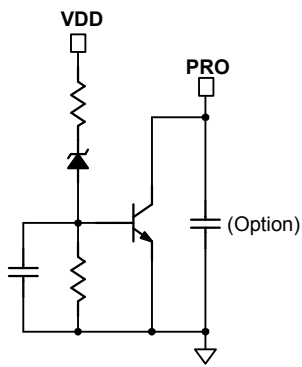

Figure 8. For VDD OVP

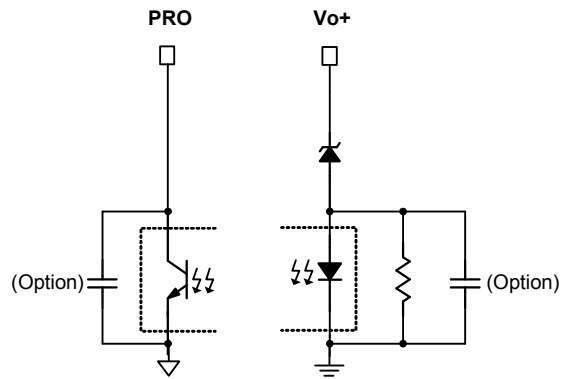

Figure 9. For V_{OUT} OVP

PCB Layout Guide

A proper PCB layout can abate unknown noise interference and EMI issue in the switching power supply. Please refer to the guidelines when you want to design PCB layout for switching power supply:

- I. The current path (1) from bulk capacitor, transformer, MOSFET, Rcs return to bulk capacitor is a huge high frequency current loop. It must be as short as possible to decrease noise coupling and kept a space to other low voltage traces, such as IC control circuit paths, especially.
- II. The path(2) from RCD snubber circuit to MOSFET is also a high switching loop, too. Keep it as small as possible.
- III. It is good for reducing noise, output ripple and EMI issue to separate ground traces of bulk capacitor(a),

- MOSFET(b), auxiliary winding(c) and IC control circuit (d). Finally, connect them together on bulk capacitor ground(a). The areas of these ground traces should be kept large.
- IV. Placing bypass capacitor for abating noise on IC is highly recommended. The bypass capacitor should be placed as close to controller as possible.
- V. In order to minimize reflected trace inductance and EMI, it is minimized the area of the loop connecting the secondary winding, the output diode, and the output filter capacitor. In addition, apply sufficient copper area at the anode and cathode terminal of the diode for heatsinking. Apply a larger area at the quiet cathode terminal. A large anode area can increase high-frequency radiated EMI.

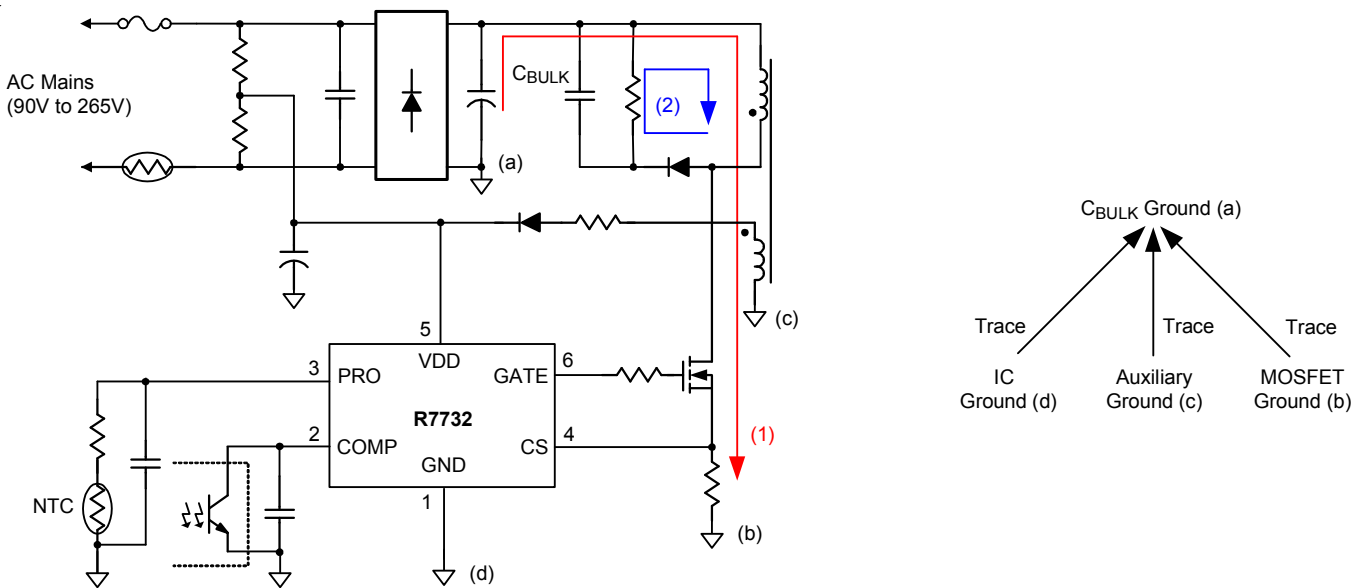

Outline Dimension

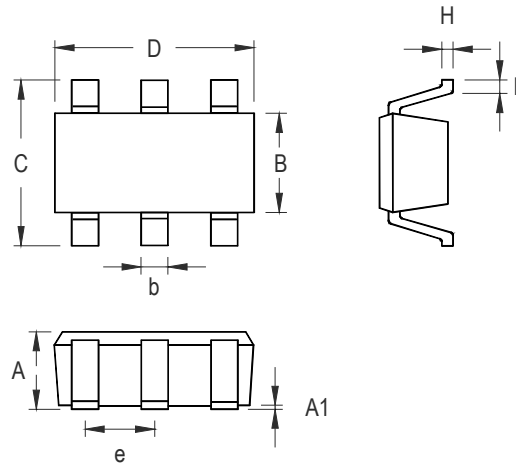

Symbol	Dimensions In Millimeters		Dimensions In Inches	
	Min	Max	Min	Max
A	0.889	1.295	0.031	0.051
A1	0.000	0.152	0.000	0.006
B	1.397	1.803	0.055	0.071
b	0.250	0.560	0.010	0.022
C	2.591	2.997	0.102	0.118
D	2.692	3.099	0.106	0.122
e	0.838	1.041	0.033	0.041
H	0.080	0.254	0.003	0.010
L	0.300	0.610	0.012	0.024

SOT-23-6 Surface Mount Package

RICHPower MICROELECTRONICS CORP.

Headquarter
 Room 2102, 1077 ZuChongZhi Road, Zhang Jiang
 Hi-TechPark, Pudong New Area, Shanghai, China
 Tel: (8621)50277077 Fax: (8621)50276966

RICHPower MICROELECTRONICS CORP.

Taipei Office (Marketing)
 8F, No. 137, Lane 235, Paochiao Road, Hsintien City
 Taipei County, Taiwan, R.O.C.
 Tel: (8862)89191466 Fax: (8862)89191465

Information that is provided by Richpower Technology Corporation is believed to be accurate and reliable. Richpower reserves the right to make any change in circuit design, specification or other related things if necessary without notice at any time. No third party intellectual property infringement of the applications should be guaranteed by users when integrating Richpower products into any application. No legal responsibility for any said applications is assumed by Richpower.